

Needs of Metals Industry Applications Drive Selection of Motion Controllers

The metals manufacturing industry is constantly evolving to require improved machine productivity and production of smaller batches of products. Machine designers and integrators are concerned with decreasing the impact of machine changeover times and the variability of operator skills and accuracy on the quality and throughput of manufacturing processes. The decisions they make can also have a major impact on decreasing lifecycle costs. Hydraulics can easily provide the power for even the heaviest-duty applications, however traditional hydraulic control systems often lack the precision to produce highly accurate and repeatable motion. For new machines and upgrades of older machines, one key to meeting cost and productivity goals is the use of a modular system design that incorporates a digital electronic motion controller.

Modular systems simplify design

Modular design of control systems is not a new concept, but the construction of modular systems using components from different vendors has been difficult. Typically, control elements from one vendor didn't communicate easily with elements from another vendor. As a result, machine designers needed to invest extra time and money in getting different controllers to work together and to play with specialized I/O. Designers often

opted to use single-vendor solutions, which could prove sub-optimal for the control task. The advent of standard industry buses has changed this. Designers can now use control system elements from different vendors with standardized interfaces to a "fieldbus" that forms the backbone of the control system architecture (see Figure 1).

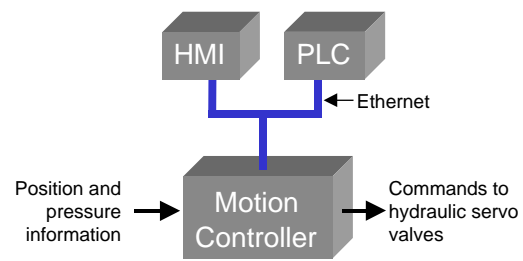

Figure 1. Modular control system based on Ethernet.

Ethernet is just one of the many fieldbuses that the designer has to choose from. Different buses, such as PROFIBUS, provide different features and advantages.

Key control system components in a typical system include the programmable logic controller (PLC), which typically acts like a functional supervisor for the machine, issuing motion commands and communicating with the human machine interface (HMI). The HMI is used by the machine operator to set up the machine's operation and view diagnostic messages.

Selecting a motion controller for metals applications

In a motion controller, high performance is often expressed in terms of support for high scan rates, the rates at which the controller tests its inputs, makes decisions, and generates controlling outputs. An advanced motion controller is capable of “closing the control loop” one thousand times per second. This is up to four times the rate of some control systems used in older machines. Faster scans and closed loop motion control mean faster machine operation and higher productivity for the machine owner.

Motion control performance is also enhanced through the proper selection of the system’s transducers, the devices that directly measure the parameters being controlled (e.g., position and pressure). For applications requiring precision and robustness, the favored position transducers are magnetostrictive linear displacement transducers (MDTs). For optimal performance, designers should look for motion controllers that provide a direct interface to popular MDT devices as well as analog and quadrature feedback devices.

Smooth motion improves quality, extends machine life

In the case of machines such as those used in metal fabrication, high quality output stems from smoothly controlled operations. Control system designers need a motion controller that has the ability to transition from hydraulic control based

on position inputs to hydraulic control based on pressure (or force), without stopping the motion. Smooth motion also requires smooth valve control, and the motion controller should provide control signals to drive a proportional valve, adding or subtracting hydraulic pressure in minute amounts. Because of the system’s smooth operation, hydraulic pressure transients and pressure overshoot are reduced, decreasing the potential for hydraulic leaks and extending the life of the machine. Some older-generation hydraulic control systems control via cylinder position sensing only, and use valving with only “open” and “closed” positions, which can result in imprecise controls and lower quality output as well as increase the need for frequent system maintenance.

Multi-axis and “hybrid” control capabilities

Some complex metal forming applications involve multiple motion axes. For these systems, designers should look for motion controllers with multi-axis control capabilities. Beyond simply being able to drive multiple actuators, good motion controllers should be able to “gear” the speed of motion of one axis with that of another, allowing the performance of the machine to be scaled to meet varying production demands and varying material types. This flexibility is very difficult or impossible to achieve with human or limit-switch-based controls.

In addition, because many metal forming machines are “hybrid” systems that have a mixture

of hydraulic and electromechanical motion sources, designers should look for multi-axis controllers that can coordinate the use of both types of motion gain the best benefits of both. Advanced controllers reduce system hardware costs by controlling each hydraulic cylinder or motor with a single valve even in position/pressure applications, as opposed to many older hydraulic motion control systems that require two valves.

Tuning for optimal performance and throughput

Machine designers must be able to optimize motion controls. In typical machine operation, the controlling PLC programs the motion controller by writing sequences of motion commands called “steps” into the controller.

Designers should look for motion controllers that are supported with development tools that make the most use of the controller/HMI connection. Using advanced software tools, designers can monitor how closely the actual motion profile matches the target, and make adjustments to control loop parameter values to reduce positioning errors.

A recent trend in the motion industry is the availability of automated tuning tools that simplify and shorten the design optimization process. An example of such a product is a Tuning Wizard (see Figure 2), that builds a set of mathematical system models and determines which model best fits the real system. The Tuning Wi-

zard next prompts the user to set the desired system response between “conservative and aggressive” using a computer mouse and slider bar and computes the optimum PID and feed-forward gains.

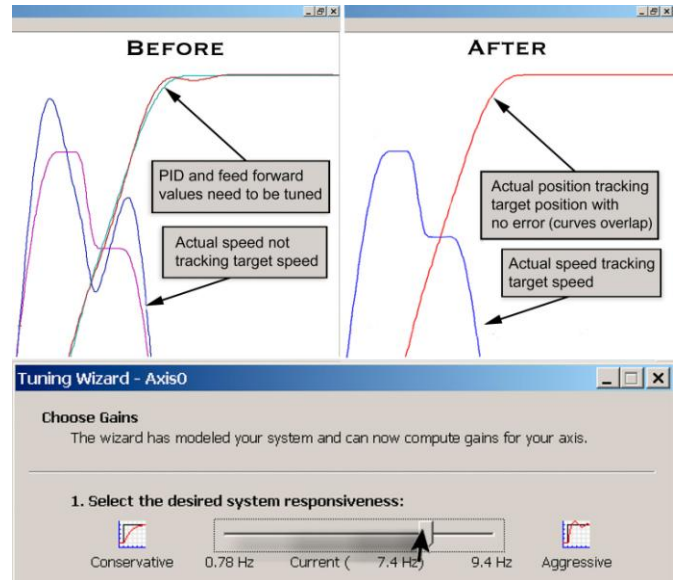

Figure 2. Delta Computer Systems' Tuning wizard adjusts motion plots to reduce motion errors.

Case study 1: Metal Forming

Large satellite antenna dishes are manufactured to very tight tolerances in three dimensions. Dishes that range from 6 to 16 feet in diameter are produced by one manufacturer by press-forming large, flat aluminum blanks to hemispherical forms (“chucks”) made of hardened steel. As the chuck and circular aluminum blank are rotated, a ball-shaped press foot (spin ball) comes into contact with the blank. As the blank and chuck continue to rotate, the spin ball forms the blank to the shape of the chuck by moving from the center to the outer edge of the blank

along the curved contour of the chuck. After the dish has been formed to the chuck, a form shoe and a forming roller are used to generate the lip on the outside circumference.

To ensure precise tolerances, a five-axis motion system is required, with some axes moving linearly while others rotate. Hydraulic power operates the spin ball and lip-forming tool, while electric motors power the rotational axes and those linear axes not involving pressure.

The system design engineers used electronic motion controllers from Delta Computer Systems to ensure repeatable operation at high tolerances and to support quick and easy reconfiguring of the controls to manufacture different sized dishes. The Delta controllers provide flexibility in handling a diverse set of motion control tasks with special ability to handle closed loop position and pressure control of hydraulic actuators. They connect directly to Ethernet, and can run up to 255 motion event steps independent of the PLC.

The most significant benefits provided by the new control system include the ability to change recipes very quickly and easily, which translates to increased manufacturing efficiency. Once the correct manufacturing parameters are established, the dish manufacturing process is precisely repeatable, meeting the tight reflective tolerances of the high quality product demanded by the manufacturer's customers, while enabling operation by a diverse range of human operators, domestically and abroad.

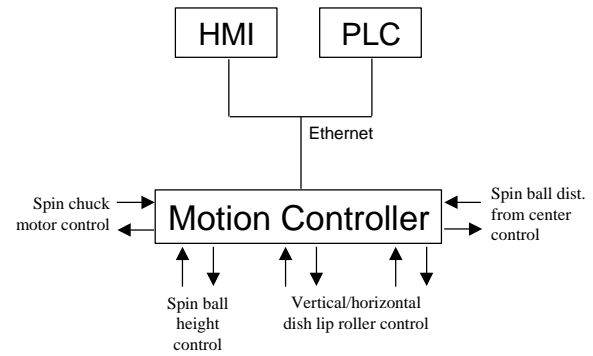

Figure 3. Metal Forming Control System Block Diagram

Case study 2: Hydroforming

Hydroforming is a manufacturing process in which a metal tube is formed by filling the inside of the tube with high pressure water and inflating the tube to fill a specially shaped mold. Hydroforming is used where the cross section of the manufactured part changes throughout the part, such as automotive suspension components and plumbing fixtures. Hydroformed parts look like they were cast, but can be made without the finishing costs and processing complexity.

Precision hydroforming has only been possible with the advent of the new generation of hydraulic motion controllers.

Figure 4 shows the main elements in one new hydroforming control system. At the core of the application is a Delta RMC100. The RMC100 controls the hydraulic rams through proportional servo-quality valves, using position feedback obtained from magnetostrictive displacement transducers (MDTs) mounted along the hydraulic piston axes. The RMC also has digital I/O interfaces, which it uses to communicate with a

PLC and to activate a valve that controls the water pressure in the tube.

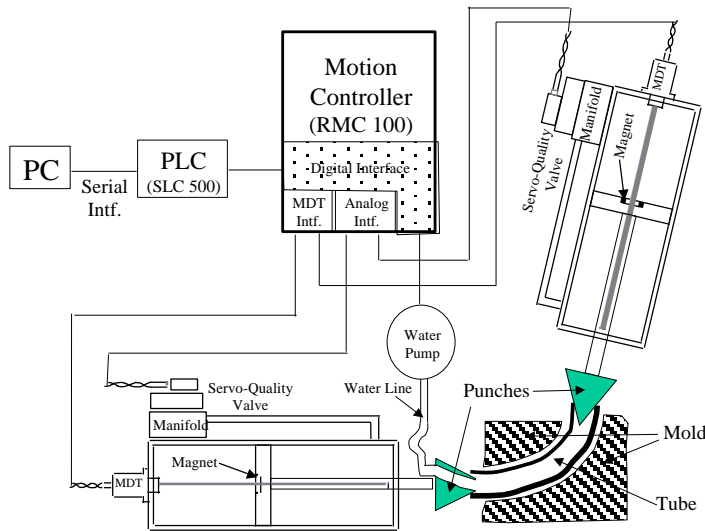

Figure 4. Hydroforming Control System

The motion controller runs through a programmed sequence of hydraulic commands to extend the punch rams to their desired positions. Next, the motion controller issues a digital command to tell the water to fill the tube. When the inflation phase is complete, the RMC turns the water off and retracts the punches. Finally, the motion controller sends a digital message back to the PLC telling it to depressurize the mold holding clamp and open the mold.

The motion steps are programmed into the RMC using a PC with a Windows-based programming interface. The sequence of motion steps are tuned to be optimal for the manufacture of a particular faucet part and then the sequence file is stored in the PC for retrieval by the manufacturing engineer as he/she sets up the machine to manufacture that part.

Delta's RMCWin development software allows the user to set control parameters and program the motion sequence by loading values into a step table in the RMC100 controller.

The Delta software allows measurements to be entered in inches rather than encoded numbers. It's very easy to change a few parameters and optimize the system's operation. RMCWin supports the graphing of actual motion profiles versus target profiles to aid the tuning process.

Case Study 3: Tube processing

As with the applications previously described, manufacturers of machines that process high quality tubing for use in automotive exhaust systems, furniture components, electrical conduit, and handles for child safety seats also have critical motion control requirements.

Tube and pipe manufacturing is all about maximizing the number of feet per minute. Older tube mills run at 200 feet per minute, while others may run at 500 or even 1000 feet per minute. The cutters that cut tube segments to length need to cut very quickly, and the effects of the cutting (burrs and dimples at the tube ends), need to be repaired just as quickly to keep up with the cutters. Machine cost and productivity benefits can be gained by integrating additional functions, such as the removal of internal and external welding imperfections along the length of the tubing. New machines must process 60 or more cut tube lengths per minute.

The sequential process supported by one new tube processing machine is shown in Figure 5.

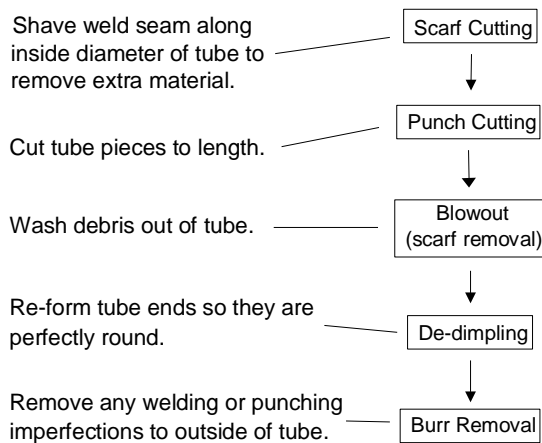

Figure 5. Tube processes

Because of all the control tasks that must be performed simultaneously, the engineers chose to employ functional partitioning in the design: Different controllers, specially suited for the tasks they perform, handle different machine functions. The system uses a PLC for master control and operator interface functions, and a motion controller to control the operation of the eight hydraulic axes. The motion controller uses four axes to control the de-dimpling/de-burring process and four axes to control the inside diameter (ID) scarf removal system (blowout).

To coordinate and control the many complex motion steps in the machine (most of the moving parts – including the rotary motors – are hydraulic), the machine designers chose an RMC100 motion controller from Delta Computer Systems.

To keep all the motors in synch, the motion controller must be capable of “electronic gearing,”

in which the rate of motion of one system element is regulated by motion elsewhere in a system.

For example, the motion of the de-dimpling punches is keyed to the motion of the chain that carries the tube past the de-dimpling station. If the chain slows down, the de-dimpler operation slows down, too. The operation is keyed off the chain indexing, not requiring the intervention of an external controller such as a PLC. Because they are tied to other motions instead of discrete events or control inputs, spline functions support smooth acceleration and deceleration.

Using an electro-hydraulic motion controller allowed the machine manufacturer to bring the benefits of hydraulics and electronic control to an application that would have required complex mechanical cams and line shafts in the past. By eliminating mechanical workings, the company was able to reduce mechanical wear and tear and use less expensive system components, such as hydraulic motors compared to electric ones.

The design also uses the rotary synchronization capability of the motion controller to move each end of the tubes down the processing line on separate independently driven chains. The main sprocket of each chain is driven by its own hydraulic motor (see Figure 6). Two motors are used to drive the chain sprockets in order to avoid flexing and to allow for variable-length pipe. For proper operation, the motors have to be synchronized, and for precise, smooth control,

each motor is controlled by a variable hydraulic valve.

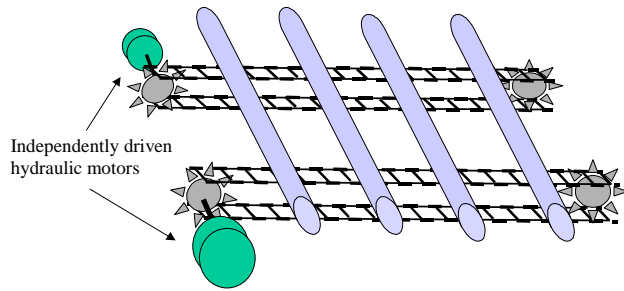

Figure 6. Rotary synchronization of motion controller

The RMC100 is unique in its ability to control up to 8 hydraulic motion axes simultaneously, while smoothly transitioning from position to pressure-based control. Programming motion steps is as easy as entering sequences of coded instructions into a control spreadsheet. Among the functions that are directly supported by the RMC100 are the spline functions that enable “electronic gearing.”

Case Study 4: Die Casting Press

Using advanced motion controllers that connect to a wide range of industry-leading components, machine builders can now select “best-of-class” system components from multiple vendors. A case in point is a new vertical die casting machine used to produce high integrity aluminum castings.

Several factors led to the choice of Profibus as the fieldbus communications backbone for the system: compatible parts availability worldwide, high-bandwidth, deterministic communications and flexible system interfaces to a wide array of

system components as specified by machine end customers.

By providing a Profibus interface between the system PLC, motion controller and peripheral devices, machine operators can set process setpoints from their HMI and gather data in a PC-based data acquisition system. The machine designers like Profibus because of its support for high, 12Mbits-per-second throughput, which supports real-time data acquisition from a wide array of system devices.

In one customer installation, Profibus provides a connection to a Fanuc 6-axis robot that sprays release agent on the die, shot sleeve and piston (see figure 7). Profibus also interfaces to a hot-oil system built in Austria (for heating the die) that sends temperature setpoints and diagnostics information to the system controller. The machine also provides a Profibus connection to a Fonderex vacuum unit used to evacuate the die prior to metal injection. Each installation uses a different combination of add-on components.

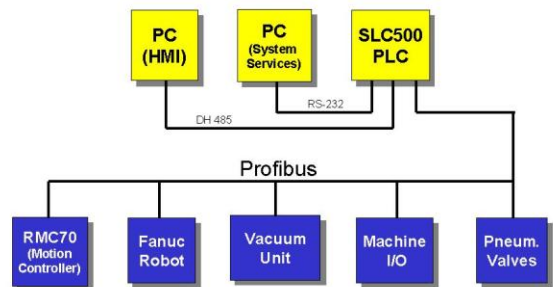

Figure 7. Die casting press control system block diagram.

To perform the closed loop hydraulic control of the shot cylinder, the machine designers needed a motion controller that: 1) interfaces directly to Profibus; 2) supports position and pressure control of hydraulics, interfacing directly to proportional servo valves; 3) is easy to program and tune; and 4) offers a good cost/performance tradeoff. To fill these requirements, the designers selected an RMC70 Series motion controller from Delta Computer Systems.

The RMC70 Series is optimized for systems that need only one or two axes of precision motion control. The controller family is supported by RMC70Tools, a software package that provides graphical tools to help designers develop control profiles and tune control loop parameters. The engineers used RMC70Tools to do the initial design and tuning and will be using it to further optimize the motion in the future.

By combining Profibus communications and Delta's precision hydraulic motion controller, the customer is confident that the new machine will produce castings that are more uniform and that have a shorter process development cycle than produced by previous die casting machines.

DELTA COMPUTER SYSTEMS

Delta Computer Systems, Inc.
11719 NE 95th Street, Suite D
Vancouver, WA USA 98682-2444
Phone: 360-254-8688
Fax: 360-254-5435
www.deltamotion.com